



# NUT, PLATE, SELF-LOCKING, RIGHT ANGLE, FLOATING, C'BORE, REGULAR HEIGHT

NAFCO IDENTIFICATION- "N"  
(LOCATION OPTIONAL)

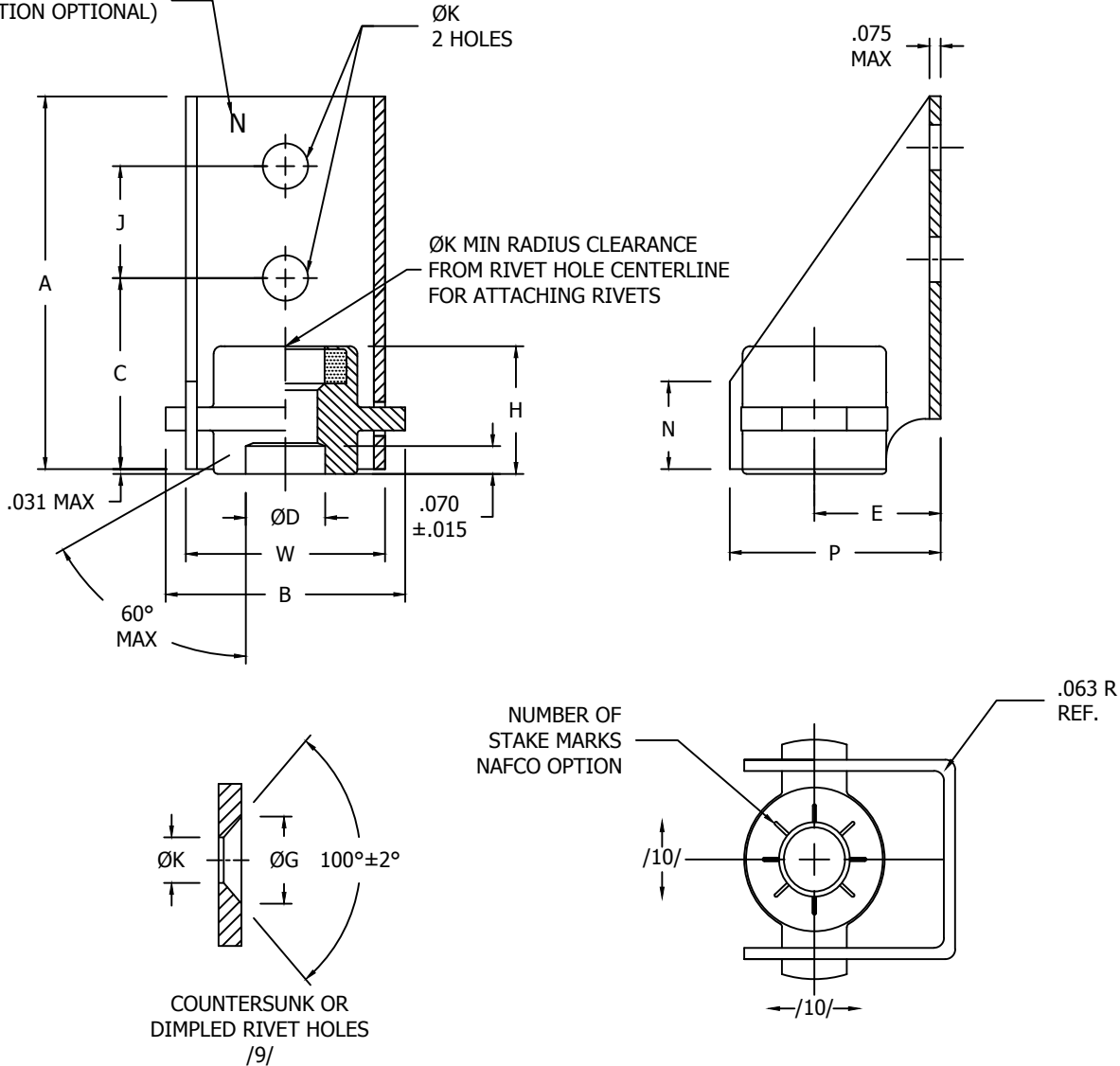

TABLE I - DIMENSIONS AND DASH NUMBERS

NAFCO PART NUMBER		THREAD	A MAX	B MAX /8/	C ±.015	ØD +.005 -.010	E ±.015	ØG ±.010	H MAX /8/	J ±.002	ØK +.005 -.000	N	P MAX	W MAX	APPROX WEIGHT LB/100
NYLON INSERT	STEEL NUT   AL ALLOY NUT														
AL ALLOY OR STEEL HOUSING		AS8879													
250°F	250°F														
NA2230-62	NA2230D-62	.1380-32 UNJC-3B	.906	.619	.484	.150	.281	.200	.343	.250	.098	.250	.531	.555	1.90
NA2230-82	NA2230D-82	.1640-32 UNJC-3B	.906	.619	.484	.180	.281	.200	.343	.250	.098	.250	.531	.555	1.80
NA2230-02	NA2230D-02	.1900-32 UNJF-3B	.906	.619	.484	.203	.281	.200	.343	.250	.098	.250	.531	.555	1.70
NA2230-048	NA2230D-048	.2500-28 UNJF-3B	.906	.687	.484	.266	.313	.200	.375	.250	.098	.296	.585	.555	2.50
NA2230-054	NA2230D-054	.3125-24 UNJF-3B	1.000	.750	.578	.328	.344	.230	.437	.250	.130	.296	.645	.631	3.00

CONFORMS TO:  
NASM25027  
AS8879

## NAFCO USA, LLC

CARSON CITY, NV 89706

PART NUMBER

## NA2230

FSC / CAGE CODE: 32387