

NUT, ANCHOR, RIGHT-ANGLE, FIXED, HORIZONTAL MOUNTING HOLES

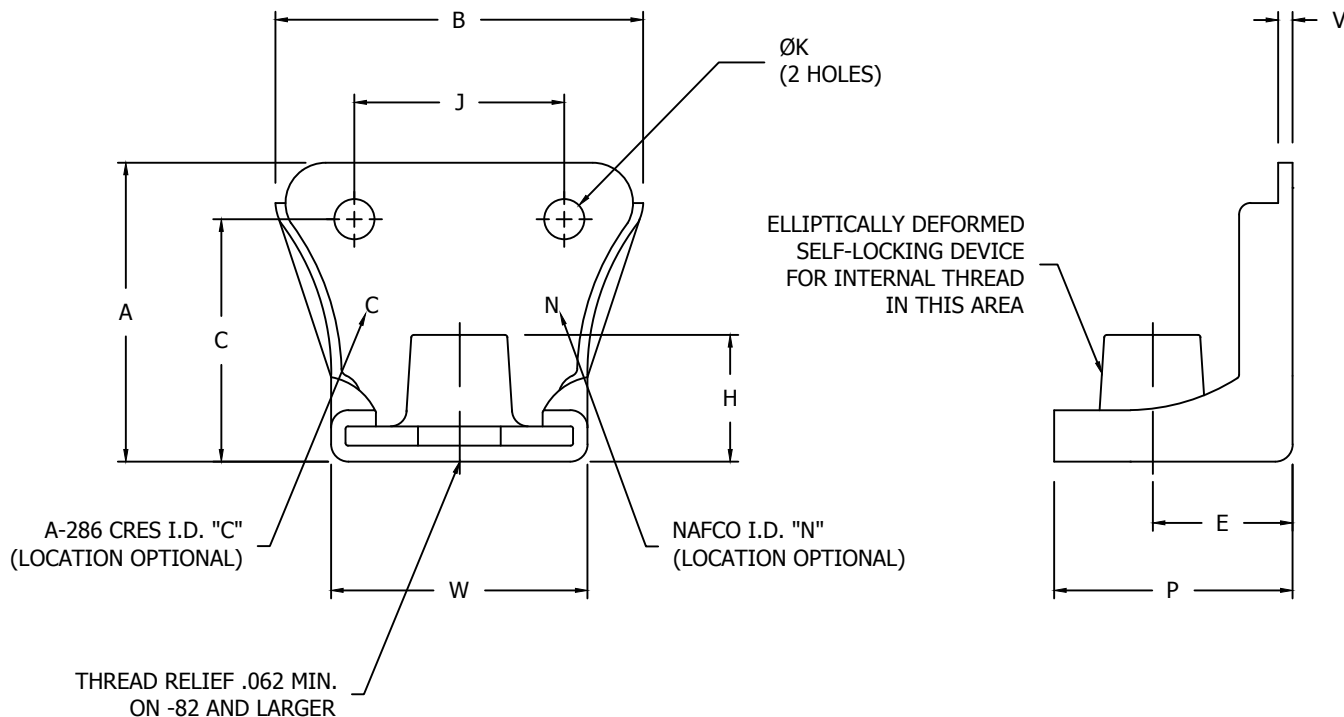

TABLE I - DIMENSIONS AND DASH NUMBERS

NAFCO PART NUMBER		NAFCO PART NUMBER		THREAD AS8879	A MAX	B MAX	C ±.005	E ±.010	H MAX	J ±.002	K +.005 -.000	P MAX	V REF	W MAX	APPROX WEIGHT LBS./100
STEEL 250°F	STEEL 450°F	CRES 800°F	CRES 900°F												
NA2132D-40	NA2132-40	NA2132CS-40	NA2132C-40	.1120-40 UNJC-3B	.635	.760	.469	.281	.160	.375	.098	.479	.025	.447	.30
NA2132D-62	NA2132-62	NA2132CS-62	NA2132C-62	.1380-32 UNJC-3B	.635	.760	.469	.281	.190	.375	.098	.479	.025	.447	.32
NA2132D-82	NA2132-82	NA2132CS-82	NA2132C-82	.1640-32 UNJC-3B	.635	.760	.469	.281	.260	.375	.098	.479	.025	.447	.33
NA2132D-02	NA2132-02	NA2132CS-02	NA2132C-02	.1900-32 UNJF-3B	.635	.760	.469	.281	.260	.375	.098	.479	.025	.447	.36

MATERIAL:

NUT -- "D" CODE -- CARBON OR ALLOY STEEL, HEAT TREATED.
 NO CODE -- CARBON OR ALLOY STEEL, HEAT TREATED.
 "CS" CODE -- A-286 CORROSION RESISTANT STEEL.
 "C" CODE -- A-286 CORROSION RESISTANT STEEL.

RETAINER -- "D" CODE -- 2024-T4 ALUMINUM.
 NO CODE -- CARBON STEEL, HEAT TREATED.
 "CS" CODE -- 302 OR 304 CORROSION RESISTANT STEEL.
 "C" CODE -- A-286 CORROSION RESISTANT STEEL.

FINISH:

NUT -- "D" CODE -- CADMIUM PLATED PER AMS-QQ-P-416, TYPE II, CLASS 3
 PLUS SOLID FILM LUBRICANT PER AS5272.
 NO CODE -- CADMIUM PLATED PER AMS-QQ-P-416, TYPE II, CLASS 3
 PLUS SOLID FILM LUBRICANT PER AS5272.
 "CS" CODE -- SILVER PLATED PER AMS2410.
 "C" CODE -- SILVER PLATED PER AMS2410.

RETAINER -- "D" CODE -- ANODIZED PER MIL-A-8625 AND DYED BLUE.
 NO CODE -- CADMIUM PLATED PER AMS-QQ-P-416, TYPE II, CLASS 3.
 "CS" CODE -- PASSIVATED PER AMS2700.
 "C" CODE -- PASSIVATED PER AMS2700.

CONFORMS TO:
 NASM25027
 AS8879

NAFCO USA, LLC
 CARSON CITY, NV 89706

PART NUMBER
NA2132
 FSC/CAGE CODE: 32387