



# NUT, SELF-LOCKING, SHANK

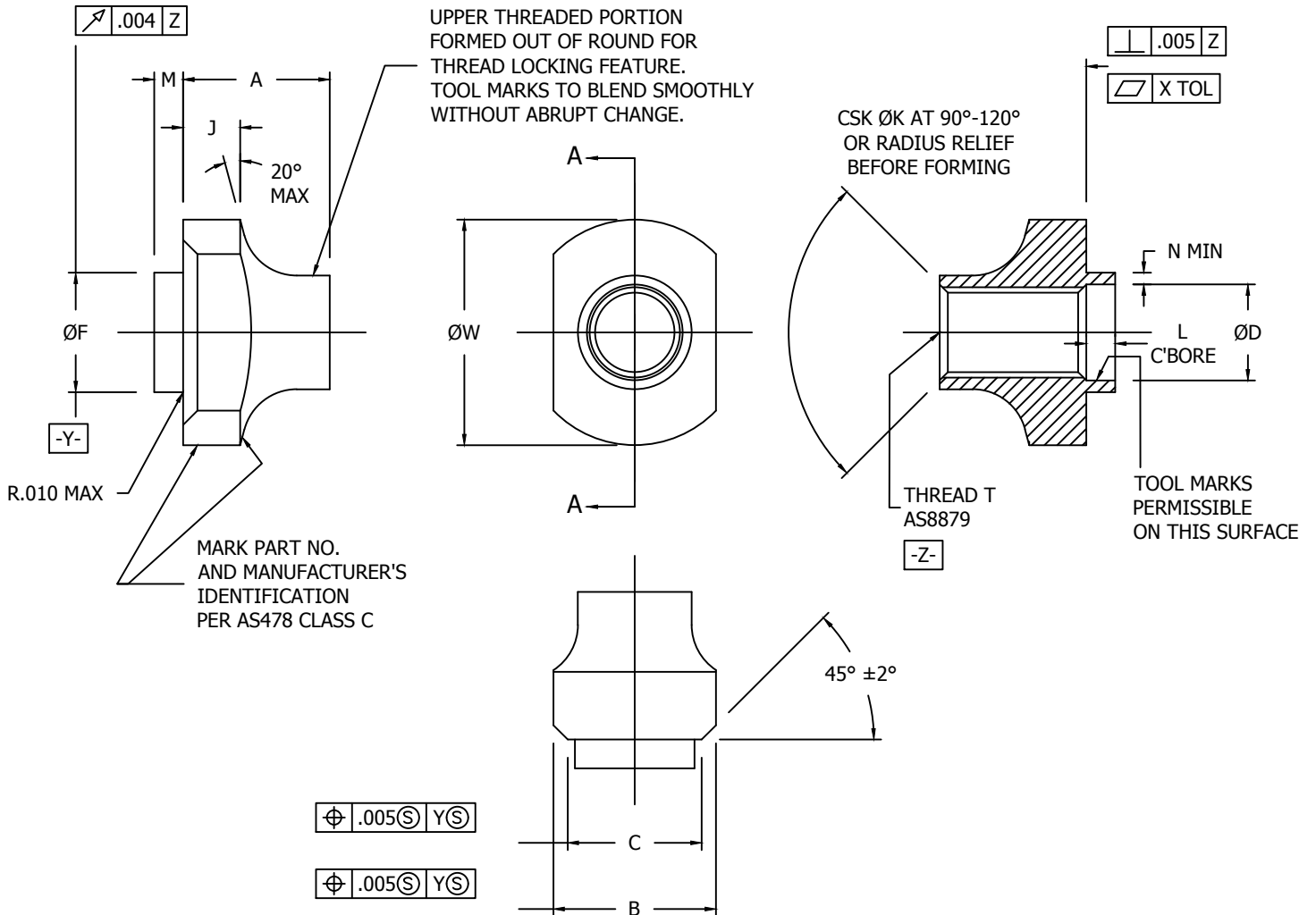

TABLE 1A - DIMENSIONS A-W

PART NUMBER	THREAD T (AS8879)	A +.005 -.010	ØB ±.005	ØC ±.004	ØD +.003 -.002	ØF ±.002	ØW ±.010
NA2407-86	.1640-36 UNJF-3B	.233	.368	.259	.171	.211	.442
NA2407-02	.1900-32 UNJF-3B	.257	.394	.285	.197	.237	.468
NA2407-048	.2500-28 UNJF-3B	.406	.450	.371	.266	.331	.625
NA2407-054	.3125-24 UNJF-3B	.468	.480	.401	.328	.394	.625
NA2407-064	.3750-24 UNJF-3B	.500	.600	.475	.401	.468	.750

CONFORMS TO:  
NASM25027  
AS8879

**NAFCO USA, LLC**  
CARSON CITY, NV 89706

PART NUMBER  
**NA2407**  
FEDERAL SUPPLY CODE: 32387