

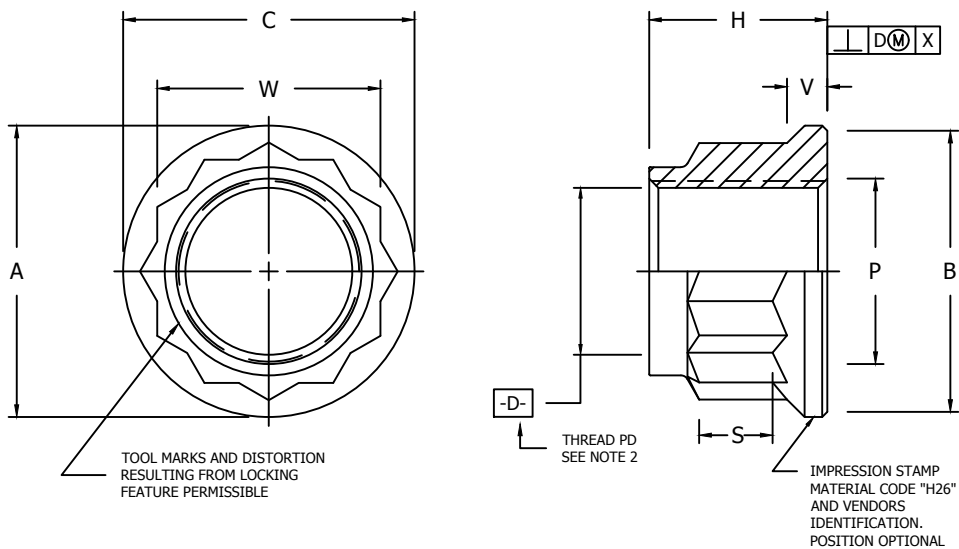

NUT, SELF-LOCKING, 12 POINT, AMS 5709



NAFCO PART NUMBER	THREAD (MIL-S-8879)	A MAX	B MIN	C MIN	H MAX	P MAX	S MIN	V MIN	W	X
NA2432-02	.1900-32 UNJF-3B	.327	.291	.277	.259	.220	.061	.023	.251 .243	.004
NA2432-048	.2500-28 UNJF-3B	.430	.379	.347	.328	.280	.086	.033	.313 .305	.005
NA2432-054	.3125-24 UNJF-3B	.515	.460	.419	.360	.342	.100	.043	.375 .367	.005
NA2432-064	.3750-24 UNJF-3B	.580	.550	.491	.458	.405	.137	.058	.439 .430	.005
NA2432-070	.4375-20 UNJF-3B	.650	.620	.561	.485	.473	.160	.069	.502 .492	.005
NA2432-080	.5000-20 UNJF-3B	.786	.756	.703	.568	.535	.176	.079	.627 .616	.006
NA2432-098	.5625-18 UNJF-3B	.875	.845	.775	.635	.597	.205	.104	.690 .679	.007
NA2432-108	.6250-18 UNJF-3B	.910	.880	.846	.705	.660	.228	.145	.752 .741	.007

MATERIAL: WASPALOY PER AMS5709.

FINISH: SILVER PLATE PER AMS2411 (.0002-.0006 THICK).

CODE: "W" FOLLOWING BASIC NUMBER INDICATES WASPALOY.
"S" FOLLOWING "W" CODE INDICATES SILVER PLATE.

NOTES:

- ALL DIMENSIONS IN INCHES.
- [-D-] -- THREADS SHALL BE IN ACCORDANCE WITH AS8879. THE UPPER THREADED PORTION OF THE NUT SHALL BE DEFORMED TO PROVIDE SELF-LOCKING FEATURE.
- SAMPLE FLOURESCENT PENETRANT INSPECT PER MIL-I-6866.
- PERFORMANCE PER AMS7253 WHEN CHECKED ON A FULL PD BOLT.

EXAMPLE CALLOUT:

NA2432 WS-048

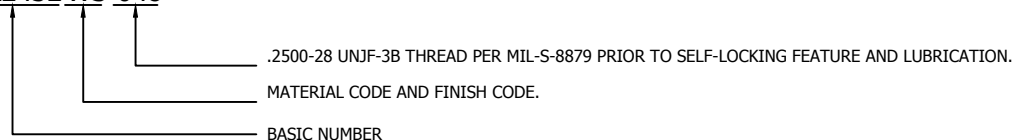

CONFORMS TO:
NASM25027
AS8879

NAFCO USA, LLC

CARSON CITY, NV 89706

PART NUMBER

NA2432

FEDERAL SUPPLY CODE: 32387