



NUT, SELF-LOCKING, SLAB

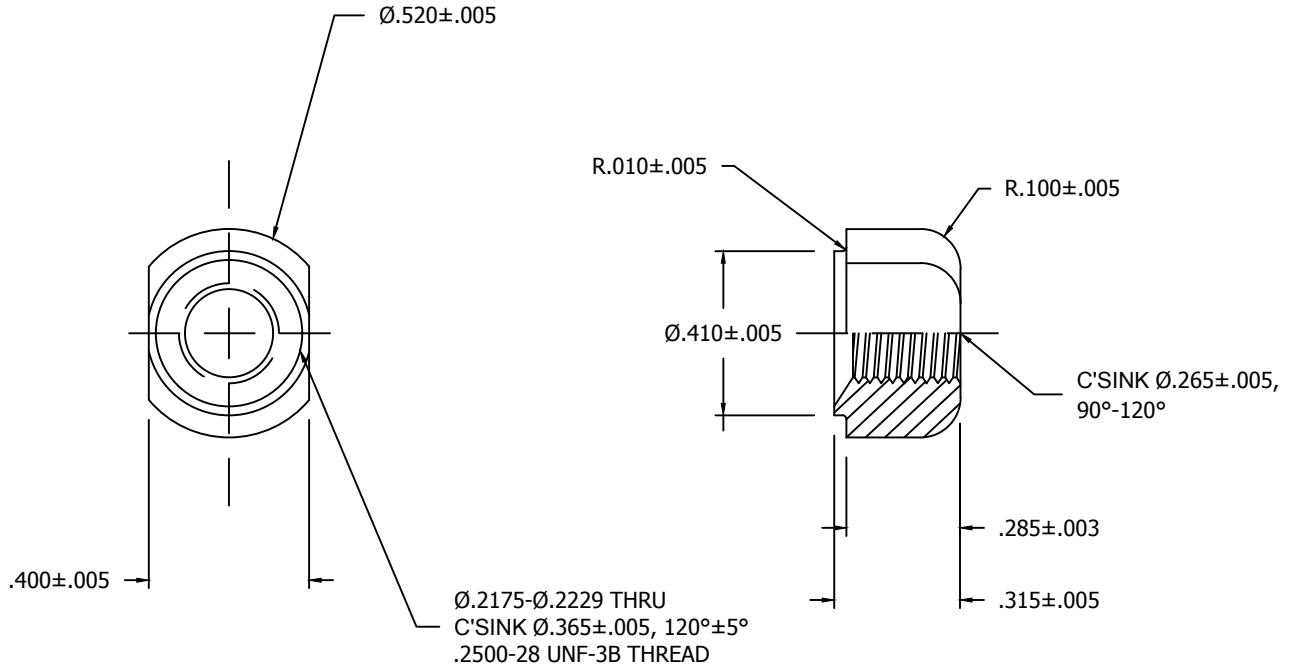

TABLE I - MATERIALS AND FINISH DATA

PART NUMBER	THREAD T	MATERIAL	SPECIFICATION	FINISH	SPECIFICATION
NA2232-048	.2500-28 UNF-3B	.5625" RND E4130 ALLOY STEEL	MIL-S-6758 AMS 6370	CAD PLATE	AMS-QQ-P-416 TY II, CLASS 2

MATERIAL: .5625" RND E4130 ALLOY STEEL.

FINISH: CADMIUM PLATED PER AMS-QQ-P-416, TYPE II, CLASS 2.
 DF - DRY FILM LUBE PER MIL-PRF-46010
 CW - CARBOWAX

EXAMPLE CALLOUT:

NA2232 - 048 CW

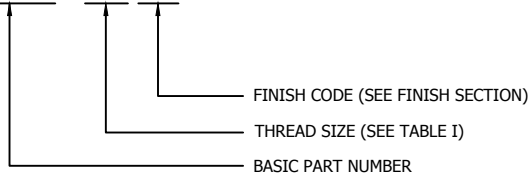

CONFORMS TO:
AS8879

NAFCO USA, LLC
CARSON CITY, NV 89706

PART NUMBER
NA2232
FSC/CAGE CODE: 32387