

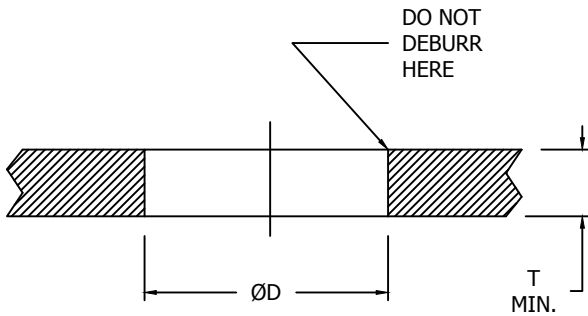

CLINCHNUT SELF-LOCKING

HOLE PREPARATION



INSTALLATION

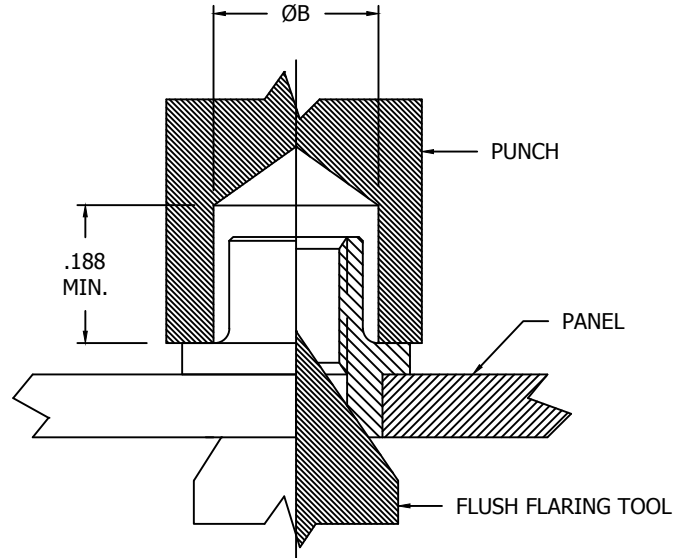

TABLE II - PERFORMANCE AND INSTALLATION DATA

NAFCO PART NUMBER	ØB +.003 -.000	ØD ±.001	T SHEET THICKNESS	APPROX INSTALL FORCE LBF	PUSH-OUT LBF MIN	TORQUE-OUT LBF-IN MIN
NA2168-26-1	.119	.125	.030 - .049	500	20	5
NA2168-26-2			.050 AND UP			
NA2168-40-1	.155	.156	.030 - .049	750	40	5
NA2168-40-2			.050 AND UP			
NA2168-62-1	.183	.188	.030 - .049	1000	60	10
NA2168-62-2			.050 AND UP			
NA2168-82-1	.208	.219	.030 - .049	1500	80	15
NA2168-82-2			.050 AND UP			
NA2168-02-1	.232	.250	.030 - .049	2500	100	18
NA2168-02-2			.050 AND UP			
NA2168-048-1	.307	.312	.030 - .049	3000	125	30
NA2168-048-2			.050 AND UP			

CONFORMS TO:
NASM25027
AS8879

NAFCO USA, LLC
CARSON CITY, NV 89706

PART NUMBER
NA2168
FEDERAL SUPPLY CODE: 32387