

**NUT, SELF-LOCKING, PLATE, TWO LUG  
FLOATING, VARIABLE C'BORE, REPLACEABLE  
NUT ELEMENT, 125 KSI FTU, 450°F AND 800°F**

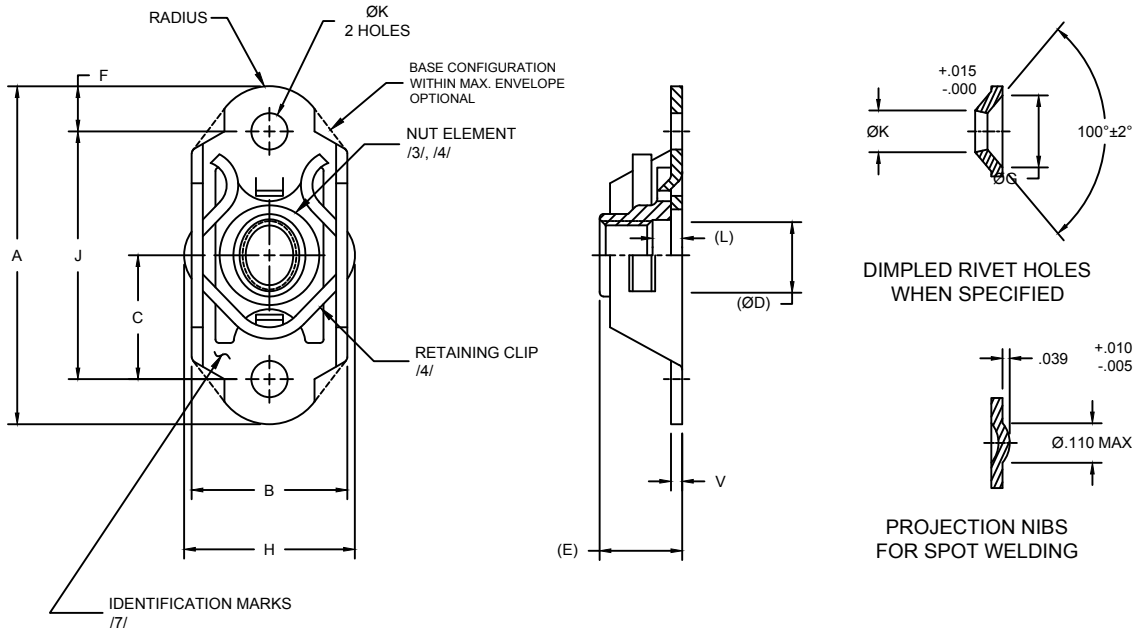

TABLE I - DIMENSIONS AND DASH NUMBERS

NAFCO PART NUMBER		THREAD (AS8879)	A MAX	B MAX	C ±.005 /3/	(ØD)	(E) MAX	F MIN	ØG ±.010	H MAX	J ±.002	ØK +.005 -.000	(L) C'BORE MIN	V ±.005	AXIAL TENSILE STRENGTH MIN. LBF (REF)	PUSH OUT MIN LBF /2/	TORQUE OUT MIN LBF-IN /2/	MAX WEIGHT LBS/100
STEEL	CRES																	
NA2361A-82-1	NA2361C-82-1	.1640-32 UNJC-3B	.948	.445	.344	.168	.250	.100	.200	.484	.688	.098	.070	.032	2,000	80	45	.57
NA2361A-82-2	NA2361C-82-2						.312						.64					
NA2361A-82-3	NA2361C-82-3						.375						.69					
NA2361A-82-4	NA2361C-82-4						.438						.74					
NA2361A-82-5	NA2361C-82-5						.500						.79					
NA2361A-82-6	NA2361C-82-6						.562						.84					
NA2361A-02-1	NA2361C-02-1	.1900-32 UNJF-3B	.948	.445	.344	.194	.250	.100	.200	.484	.688	.098	.070	.032	2,825	200	90	.57
NA2361A-02-2	NA2361C-02-2						.312						.64					
NA2361A-02-3	NA2361C-02-3						.375						.69					
NA2361A-02-4	NA2361C-02-4						.438						.74					
NA2361A-02-5	NA2361C-02-5						.500						.79					
NA2361A-02-6	NA2361C-02-6						.562						.84					
NA2361A-048-1	NA2361C-048-1	.2500-28 UNJF-3B	1.292	.547	.500	.254	.295	.125	.200	.584	1.000	.098	.070	.032	5,060	225	160	1.07
NA2361A-048-2	NA2361C-048-2						.357						1.17					
NA2361A-048-3	NA2361C-048-3						.419						1.26					
NA2361A-048-4	NA2361C-048-4						.481						1.34					
NA2361A-048-5	NA2361C-048-5						.543						1.44					
NA2361A-048-6	NA2361C-048-6						.605						1.52					
NA2361A-054-1	NA2361C-054-1	.3125-24 UNJF-3B	1.292	.643	.500	.317	.344	.125	.230	.720	1.000	.130	.070	.040	8,000	250	280	1.82
NA2361A-054-2	NA2361C-054-2						.400						1.87					
NA2361A-054-3	NA2361C-054-3						.461						2.00					
NA2361A-054-4	NA2361C-054-4						.524						2.11					
NA2361A-054-5	NA2361C-054-5						.586						2.22					
NA2361A-054-6	NA2361C-054-6						.649						2.33					
NA2361A-064-1	NA2361C-064-1	.3750-24 UNJF-3B	1.292	.760	.500	.379	.380	.125	.230	.840	1.000	.130	.070	.050	11,900	125	240	2.40
NA2361A-064-2	NA2361C-064-2						.430						2.55					
NA2361A-064-3	NA2361C-064-3						.500						2.80					
NA2361A-064-4	NA2361C-064-4						.560						2.95					
NA2361A-064-5	NA2361C-064-5						.635						3.10					
NA2361A-064-6	NA2361C-064-6						.690						3.25					

CONFORMS TO:  
NASM25027  
NAS3350, CLASS 1  
AS8879

**NAFCO USA, LLC**  
CARSON CITY, NV 89706

PART NUMBER  
**NA2361**  
FSC / CAGE CODE: 32387